

Hervey Bay Faceting Competition 2021

Sponsored by

Hervey Bay Gem & Mineral Club



Conducted by the HBGC Inc.

The competition will be conducted in two Divisions.

1 Novice Division

2 Open Division

All Judging and rules shall be as per the Competition and Judging Manual AFLACA.

Each Division will consist of two (2) stones; the Judges points are added together and the competitor with the highest points for the two stones will win the Division.

Boxes containing entries must be clearly marked with division and the name of the gem material. The entrant's name must **NOT** appear on the box, but **MUST** be enclosed separately for identification purposes.

Minimum size in all sections is 6mm on the shortest axis of outline shape viewed from above.

Stones more than 0.1mm below minimum size will be ineligible.

Entries with official entry form must be received no later than the 7th June 2021 to Jan Braddy, P.O.Box 3007, Pialba 4655

All entries will be displayed and results announced at the Hervey Bay Gem & Mineral Show on the 3rd July 2021

Entries, Judging sheets and prizes where applicable will be available for collection at the Gem show from 3PM on Sunday the 4th of July. If you want your entry posted back, then please include return postage.

Entries and awards not collected will be mailed to contestants by the 20th July 2021

Section numbers reflect the numbers in the AFLACA Manual and points allocation are also as per the Manual.

Only QLACCA or AFLACA affiliated club members are eligible to enter.

Competition Sections

Novice

Both novice sections must be cut to be eligible for the Prizes.

Section N.8B.1 Standard Round Brilliant Cut in CZ

Section N.10.1 Tessellation 12 Cut in CZ

Open

Both open sections must be cut to be eligible for the Prizes.

Section O.10.1 Square Brilliant one, Specified size: 8mm. Cut in Colourless Topaz

Section O.10.2 Wieland Star, Cut in Coloured Quartz

Trophies:

Open & Novice

Certificate + parcel of CZ rough

1st Place Starter pack laps

2nd Place Loupe

3rd Place 300/50000 4 prong grabber

Hervey Bay Faceting Competition 2021
NOVICE DIVISION SECTION N.8B.1
To be cut in CZ. Number of Meets: P25 + C32 =57 Meets

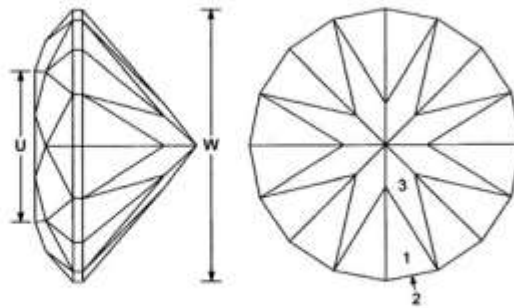
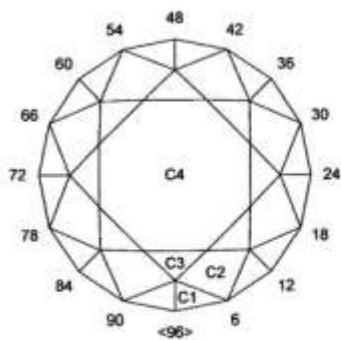

Standard Round Brilliant

angles for CZ
 Angles for R.I. = 2.160
 57 + 16 girdles = 73 facets
 8-fold, mirror-image symmetry
 96 index
 $L/W = 1.000$ $T/W = 0.556$ $U/W = 0.556$
 $P/W = 0.420$ $C/W = 0.139$
 $Vol./W^3 = 0.210$

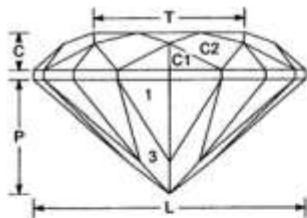

PAVILION

1	41.49°	03-09-15-21-27-33-39-45- 51-57-63-69-75-81-87-93	Cut to TCP
2	90.00°	03-09-15-21-27-33-39-45- 51-57-63-69-75-81-87-93	Set size of stone
3	40.00°	06-18-30-42-54-66-78-90	Meet 1,2 at girdle

CROWN

C1	42.00°	03-09-15-21-27-33-39-45- 51-57-63-69-75-81-87-93	Set girdle width
C2	35.00°	06-18-30-42-54-66-78-90	Meet C1 at girdle
C3	20.00°	96-12-24-36-48-60-72-84	Meet C1, C2
C4	0.00°	Table	Meet C2, C3

Hervey Bay Faceting Competition 2021
NOVICE DIVISION SECTION N .10.1
To be cut in CZ. Number of Meets P13, C12 = 25

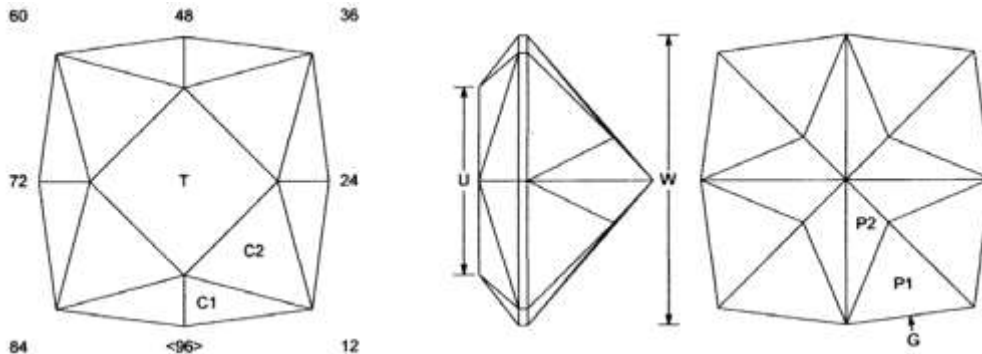

Tessellation 12 (F)

By Arya Akhavan (October 2012)

angles for CZ

Angles for R.I. = 2.160

29 + 8 girdles = 37 facets

4-fold, mirror-image symmetry

96 index

L/W = 1.000 T/W = 0.648 U/W = 0.648

P/W = 0.434 C/W = 0.136

Vol./W³ = 0.233

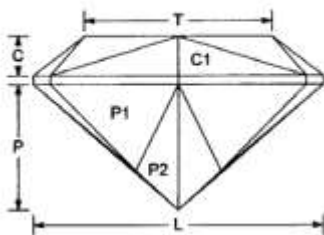

PAVILION

P1	42.00°	02-22-26-46- 50-70-74-94	Cut to centerpoint
G	90.00°	02-22-26-46- 50-70-74-94	Set stone size
P2	41.00°	01-23-25-47- 49-71-73-95	Meet P1, G

CROWN

C1	38.00°	02-22-26-46- 50-70-74-94	Set girdle width
C2	19.00°	12-36-60-84	Meet G, C1
T	0.00°	Table	Meet C1, C2

Hervey Bay Faceting Competition 2021

OPEN SECTION O10.1 Number of Meets P25, C28 = 53

Material Colourless Topaz
 Specified Size 8mm

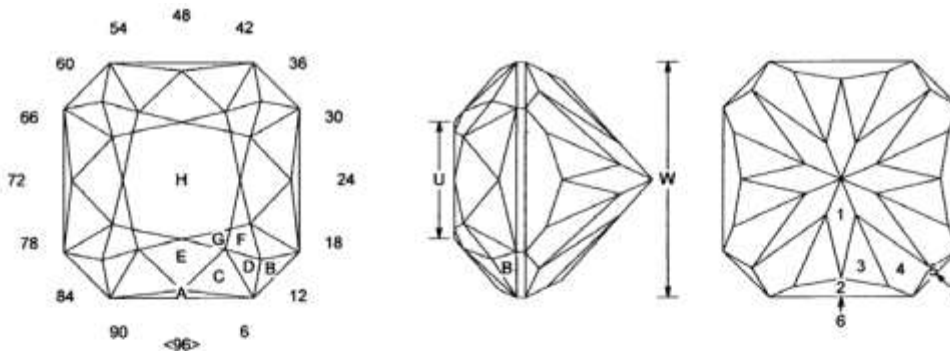

Square Brilliant One

by John Bailey
 Angles for Topaz
 Angles for R.I. = 1.610
 73 + 8 girdles = 81 facets
 4-fold, mirror-image symmetry
 96 index
 $L/W = 1.000$ $T/W = 0.497$ $U/W = 0.497$
 $P/W = 0.540$ $C/W = 0.264$
 $Vol./W^3 = 0.377$

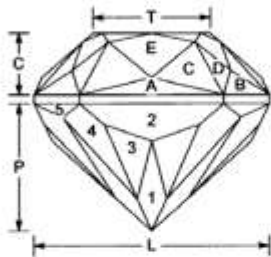

PAVILION

1	42.00°	96-12-24-36- 48-60-72-84	Cut to PCP
2	64.20°	96-24-48-72	Cut to point of 1
3	43.90°	03-21-27-45- 51-69-75-93	meet 1, 2
4	43.50°	09-15-33-39- 57-63-81-87	meet 1,3
5	59.10°	12-36-60-84	meet point of 1
6	90.00°	96-24-48-72	level girdle
7	90.00°	12-36-60-84	level girdle

CROWN

A	65.70°	96-24-48-72	set girdle width
B	48.20°	12-36-60-84	level girdle
C	45.50°	02-22-26-46- 50-70-74-94	meet A,B
D	43.40°	10-14-34-38- 58-62-82-86	meet C,B
E	41.00°	96-24-48-72	meet A,C
F	41.00°	12-36-60-84	meet B,D
G	26.00°	03-21-27-45- 51-69-75-93	Meet E,F
H	0.00°	Table	Meet F,G

Hervey Bay Faceting Competition 2021

OPEN DIVISION SECTION O.10.2

To be cut in Coloured Quartz Number of Meets P41, C40 = 81

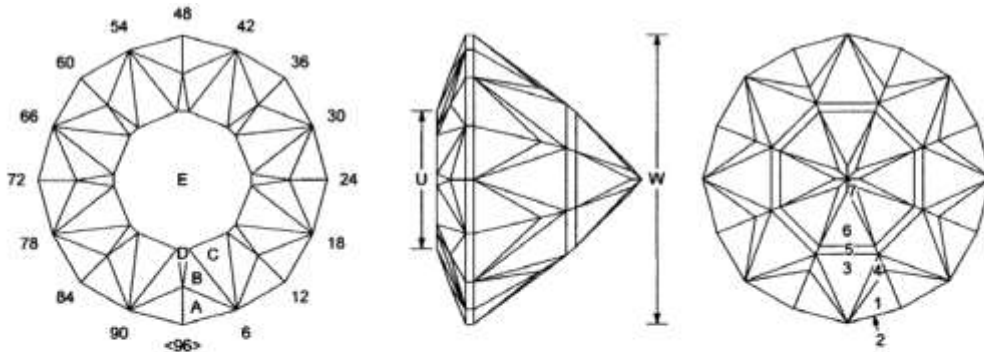

Wieland Star (Germany 2009)

Angles for Quartz
 Angles for R.I. = 1.540
 113 + 16 girdles = 129 facets
 8-fold, mirror-image symmetry
 96 index
 $L/W = 1.000$ $T/W = 0.477$ $U/W = 0.477$
 $P/W = 0.581$ $C/W = 0.099$
 $Vol./W^3 = 0.235$

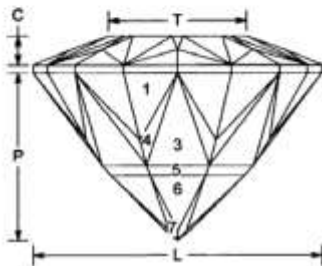

PAVILION

1	58.49°	04-08-16-20-28-32-40-44-52-56-64-68-76-80-88-92	Cut to form TCP
2	90.00°	04-08-16-20-28-32-40-44-52-56-64-68-76-80-88-92	Level Girdle
3	53.46°	96-12-24-36-48-60-72-84	Cut to meet girdle
4	56.55°	03-09-15-21-27-33-39-45-51-57-63-69-75-81-87-93	cut to meet girdle at 1
5	48.54°	96-12-24-36-48-60-72-84	Meet 4
6	45.18°	96-12-24-36-48-60-72-84	create step cut
7	42.00°	06-18-30-42-54-66-78-90	meet 5 & 6 form PCP

CROWN

A	22.94°	04-08-16-20-28-32-40-44-52-56-64-68-76-80-88-92	set girdle
B	21.40°	05-07-17-19-29-31-41-43-53-55-65-67-77-79-89-91	meet A at girdle
C	21.00°	06-18-30-42-54-66-78-90	meet A,B at girdle
D	19.38°	96-12-24-36-48-60-72-84	Meet A,B
E	0.00°	Table	

This Page is left for your workings

Hervey Bay Faceting Competition 2021

ENTRY FORM

Name: Miss. Mrs. Ms. Mr.

Address

.....

Postcode.....

Club

Novice		
Section	Material	Colour
N. 8B.1		
N. 10.1		

Open		
Section	Material	Colour
O.10.1		
O.10.2		

Notes for Entrants:

1. Decide which Sections you are going to enter.
2. Write Name and colour of material in appropriate space for each section entered.
3. Complete the section below.
4. Include return Postage. Send your entries and this form to:

Jan Braddy, P.O Box 3007, Pialba, 4655

To Arrive no later than 7th June 2021

I declare that my entries are all my own work, have not won a first prize in any competition at the same level and division

Entrants signature.....Date.....

Office use only

Received..... Checked.....Code.....

Address

.....

Postcode.....